

FreedomAlert[®]

Enjoy the Freedom of Independent Living

With DECT Technology

INSTALLATION & OPERATION INSTRUCTIONS **Model #35911**



PLEASE READ THIS MANUAL COMPLETELY AND SAVE IT FOR REFERENCE.

Thank you for choosing FreedomAlert® – the most unique Personal Emergency Response System in the world, and covered by both US and Canadian patents.

FreedomAlert is your personal link to Family, Friends, or Emergency Personnel when needed. FreedomAlert allows you to program up to 4 numbers to be reached at the push of a button.

With FreedomAlert - there are:

No Activation Costs

No Contracts

No Monthly Fees

Up to 4 user programmable contacts to call anytime. You can personalize the system with a flick of a slide switch on the Base unit to:

Call up to 4 custom contacts

Call up to 4 custom contacts & then the 911 emergency operator

Or just the 911 emergency operator.

Because you are speaking through the pendant, FreedomAlert allows you to personally communicate your emergency from anywhere in your home or yard. Emergencies can happen anyplace. And just one button activation.

Traveling? Whether you are moving across town or going to visit the grand kids across the country - just unplug your FreedomAlert from the phone jack, unplug the power adaptor and throw it in your suitcase. When you get to your destination, simply plug it into the local phone jack and power outlet. No additional programming needed. And if you call 911, they will automatically have the local 'caller ID' of that location.

Voice prompts provide easy set-up and testing.

Base unit comes with 4 rechargeable batteries to provide up to 24 hours of standby power in the event of a power outage.

Need others to share the system in your home. No problem, you can add a total of up to 4 Pendants and Emergency Wall Communicators to one Base unit as you wish.

Note: Spanish and French instructions can be downloaded from our website.

TABLE OF CONTENTS

Overview of the FreedomAlert	2
Contents of FreedomAlert kit	4
Limitation of Liability	5
Installing the Batteries	6
Connecting the Base Unit	
Power & Telephone Connections.....	8
Key to LEDs on the Product	8
How to Handle VoIP & DSL.....	9
Location of Base Unit	10
Base Unit Options & Features	
Friends List and Emergency Operator	10
Programming the Unit	
Programming Telephone Numbers	11
Telephone Number Programming Worksheet.....	12
Programming Special Features	14
Adding Additional Pendants to the System	16
Operating the FreedomAlert	
Operating the Pendant.....	17
Answering an Incoming Call with the Pendant	18
Holding the Pendant.....	18
Hanging Up.....	18
Lanyard, Belt Clip or Wrist-Strap.....	19
Battery Check.....	19
System Check.....	20
Emergency Dialing Using the Panic Button	22
Operating Range	22
Water Resistance.....	22
Periodic Testing / Maintenance	
Replacing Batteries	23
Out of Service Storage or Transportation	23
Troubleshooting Guide	24
Disclaimer / General Warnings & Precautions / Safety	28
Warranty	30
Replacement Parts / Additional Accessories Available	33
Product Specifications	34

Contents of the FreedomAlert Kit:

The items below are included with your FreedomAlert .



Pendant



**Rechargeable Li-Ion Special
Pendant Batteries - 2 Pieces**



Belt Clip



**Wrist / Walker / Wheelchair
strap**



Lanyard



Base Unit



Rechargeable AA Batteries - 4 Pieces



AC Adapter



Phone Cord

Limitation of Liability

This page is a summary of the Disclaimer and Limited Warranty disclosed in full at the end of this instruction manual. Read them.

The purchaser agrees by using this product to the terms and conditions below and in the Disclaimer and Limited Warranty. The purchaser also agrees to read and follow all instructions and warnings on the product and contained within these Installation and Operation Instructions.

It will be the sole responsibility of the purchaser and any user to assure that the FreedomAlert product is installed and programmed properly, and that the unit is used and maintained correctly. This includes, but is not limited to, periodic use to assure that the FreedomAlert, including batteries, are in proper working order, that the unit is located in an appropriate location in the home, that the electrical outlet is supplying power, and that the user has been educated as to the operation and functionality of the product as a whole.

The FreedomAlert equipment is not designed or guaranteed to prevent any loss or injury. This Limited Warranty and Disclaimer of Liability set forth in full at the end of this instruction manual constitutes the terms of sale and use of the FreedomAlert (and accessories) equipment, and if, notwithstanding these terms of sale and use of the product, there should arise any liability on the part of LogicMark LLC as a result of any cause whatsoever, regardless of whether or not such loss, damage, or personal injury was caused by or contributed to by LogicMark's negligence to any degree or failure to perform any obligation or strict products liability, such liability will be limited to an amount paid by the Purchaser for the product or \$300, whichever is greater.

Further, LogicMark has no obligation to assure that calls are made, received or responded to, nor is LogicMark responsible for acts, or consequences of the acts, of those responding.

LogicMark provides no monitoring service for this product. It is up to the persons at the numbers called to respond in an appropriate manner.

Installing the Batteries

Pendant - small white batteries. The Pendant requires one of the white/Li-Ion (Lithium Ion) batteries at any given time. The pendant should be able to run up to 4 months on a fully charged battery. The second battery is to be charging in the Base unit when not being used in the Pendant. There is no problem of over charging while in the base charger.

To install the battery - unscrew the battery cap of the Pendant. Install the battery with the negative side up facing the cap. Screw the cap back down snugly on the Pendant.

The Pendant Batteries are shipped from the factory with a partial charge – and will only standby a short period of time. Your unit has 2 pendant batteries and it is recommended to exchange the battery that is in the base charger with the battery in the pendant after the first day of use. This will assure the battery in the pendant is fully charged and will standby several months before needing to be exchanged/charged again.

You can check the battery status at any time by simply pushing the gray battery test button on the back of the Pendant for a second.

Place the extra Pendant battery into the front charging area of the Base unit so that it will charge and be ready when its time to swap the batteries around. The LED on the right side will glow red when charging and green when fully charged.

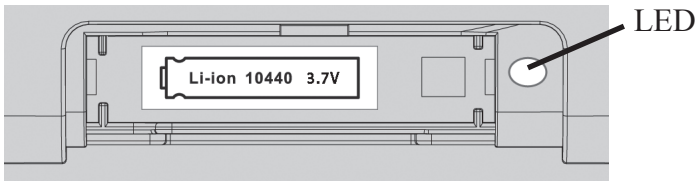

NOTE: These white batteries are very special batteries that are not available at your local store. See Specification on page 34 for more details, or contact LogicMark to purchase replacement batteries. You can also purchase them on-line at www.PrimaryVolt.com

Base - Larger AA Rechargeable Batteries: The Base unit requires 4 rechargeable NiMH batteries. Unlike the Pendant battery - these are readily available in many retail stores. Any value of 2400 or higher mAh capacity is fine. These are to provide you with 24 hours of battery back-up protection in the event of a power failure. They will not be damaged by continually charging in the base unit.

When you first get your unit - these batteries will probably be low, or even fully discharged - and will need to be charged for 24 hours before being able to provide you the 24 hour battery back-up protection.

Remove the cover on the bottom of the Base unit. Install the 4 batteries as shown in the plastic engraving in the battery compartment area. A few seconds after you install these, you might hear “Running on battery power”. When the unit is operating on the backup batteries, it will announce “Running On Battery Power” twice and the RED Power LED will continue to flash. If power is not restored with in an 8 hour period, the unit will start to announce “Running On Battery Power” once every 30 minutes until power is restored or the back up batteries are depleted. (If you do not hear this announcement, and the Power LED is on solid, that means that you have already plugged in the power adaptor).

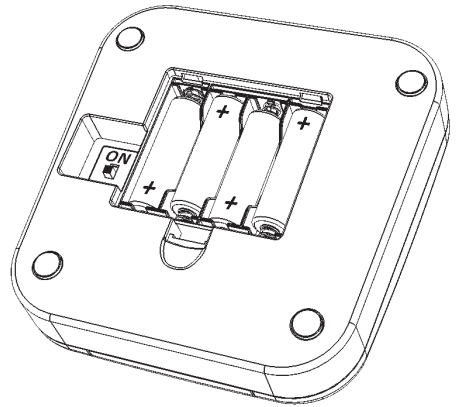

NOTE: the voice prompts of “battery is OK” etc only apply to the pendant battery - not to the status of the base unit’s batteries. It is recommended that you replace the base unit batteries with a new set of similar batteries every 2 years.

Master ON/OFF switch:

FreedomAlert has a Master ON/OFF switch on the bottom of the base unit – just left of the rechargeable batteries for the base unit. This switch controls all power – back up batteries and power from the AC adapter. This switch should be ON at all times while the unit is in use. This switch should only be turned OFF if the FreedomAlert unit is taken out of service – during transportation or no longer needed.

Connecting the Base Unit

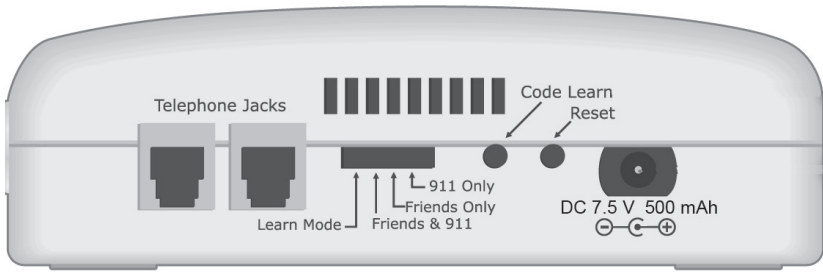

Power Connection. Simply plug in the AC Adapter in to the nearest electrical outlet. Plug the other end of the AC power adapter into the Base unit. You need to push the plug into the opening in the Base unit and twist 90° clockwise to lock in place. To remove in the future, simply rotate 90° counter-clockwise and pull outward.

Caution: Do not plug the AC Adapter into an outlet which is controlled by a switch. The switch could accidentally be turned off, thus rendering the Base unit inoperable after approximately 24 hours when the back up batteries become discharged.

Telephone Connection. No special phone line or special service is required to use your FreedomAlert. It works the same way as any cordless phone. (**Touch Tone service is required**). Simply plug one end of the telephone cord into your telephone jack in the wall, and the other end into either one of the telephone jacks at the back of the Base unit. Note - you will feel a 'click' when the jacks are firmly seated in the wall and the Base unit jack receptacles.

If you need to plug a conventional telephone into same outlet used by the FreedomAlert, simply plug the telephone into the spare jack at the back of the Base unit.

Key to LEDs on Product:

Here is the key for the LEDs on the Base unit and the Pendant:

BASE RED LED functions:

- Off: No AC power/No Back-up Battery Power
- Solid: AC power
- Flashing: Running on Battery Back-up

BASE GREEN LED functions:

- Off: Standby
- Solid: Dialing/Talking or Learn Mode
- Flashing: Pendant Learning or Low Pendant battery

PENDANT LED (single RED LED) Functions:

- Off: Standby
- Solid: Dialing or Talking
- Flashing: Pendant Learning

How to Handle VoIP & DSL

If Your Phone System is VoIP: Voice-over-Internet Protocol (VoIP) is a telephone service that sends your call over the Internet instead of through the regular telephone system. FreedomAlert will work well on most VoIP systems.

It is important (if you haven't already done so) that you register your physical address with your VoIP provider and check to insure that 911 service is available to you.

If you are unsure if your phone system uses VoIP, or to find if your VoIP system is capable of calling 911, please contact your telephone service provider.

To install FreedomAlert, simply plug the product into the telephone jack (or adaptor jack) that you would normally plug a regular telephone into.. Note, if you have both a working traditional phone line AND a VoIP phone system we recommend connecting the FreedomAlert system to the traditional phone line.

For more information on using the FreedomAlert product with your VoIP system, visit our website at www.LogicMark.com and view the FAQ under the OUR PRODUCTS tab.

How to Handle DSL: If your home has DSL service for your computer, you will need to use a DSL filter in line with the FreedomAlert OR IT WILL NOT WORK. This filter can be obtained from a local electronics supplier or your DSL service provider. See illustration to the right.

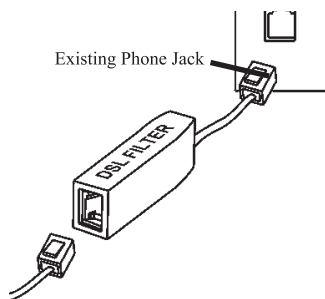

To FreedomAlert

Locating the Base Unit: For best results and longest range, locate the Base unit in an area away from household appliances which could present electrical interference. These include microwave ovens, refrigerators, televisions, electric mixers or blenders, hair dryers, wifi routers or other cordless phones. Do not place on a metal surface.

If more than one FreedomAlert is to be used in one home, it is recommended that the Base units be located at least 10' apart.

Base Unit Options and Features:

The FreedomAlert can work right out of the box with no programming. To avoid programming any telephone numbers, simply slide the slide switch at the back of the Base unit to the “**911 Only**” mode. Then, when you push the blue button on the Pendant - you will be immediately connected to 911 emergency services. **Note: If no Friend’s list phone numbers are entered or a mistake was made while programming the Freedom Alert, it will automatically default to 911 for each of the 3 slide switch settings.**

If you choose not to program any Friends numbers, simply skip these next steps on Programming Telephone Numbers and jump to page 14.

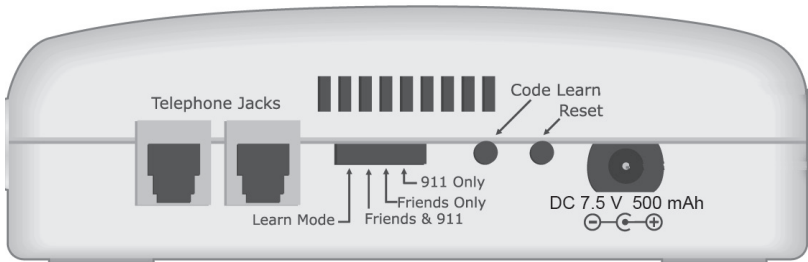

Friend’s List and Emergency Operator.

In addition to being able to call 911, you can also program up to 4 telephone numbers of your choosing. You need not program all 4 - just one if you like. Typically, you might have it programmed for 2 numbers - to call your neighbor and if they are not available, to call a family member. Even if you do program a number or more into the Base unit - you can still at any time choose to call “**911 Only**” by just sliding the switch at the back of the Base unit. Your numbers remain in memory and will be ready for use when you slide the slide switch back to one of the “**Friends**” position. Note: Disconnecting power or changing batteries does not erase the numbers.

How does the Base unit know when to go to the next number? The base unit will first dial the first number in the “**Friends**” list. About 10 seconds into the conversation, the Base unit will interrupt the call and announce “*This is an emergency call. If you want to continue this call - Press 5 now. Otherwise, we will hang up and call the next contact or emergency operator*”. At this point - the person that is being called must press the “5” key on their telephone if they want to continue the call. If they don’t press “5”, then the Base unit will assume they do not want to talk, or that it may be an answering machine or a child - at which point it hangs up and goes on to the next number. It is important to instruct the people you have programmed into your “**Friends**” list to press “5” when they get this call, and when they hear this message. NOTE: the “Press 5” message is NOT played anytime the FreedomAlert unit is calling 911.

Programming the Base Unit

Programming Telephone Numbers:

If you choose to only contact 911 - and not a custom telephone number - skip these next steps (and go to page 14) - and make sure your slide switch on the back of the Base unit is set to “**911 only**”.

NOTES:

- As you program the system using your telephone, you will hear the base unit speak each number as it is pushed.
- Dial slowly and listen for each number to be announced. If you did not hear the announcement - the number was not recorded.
- The FreedomAlert can learn telephone numbers up to 32 digits long, and you do not have to program all 4 numbers
- Need to add a pause in your number sequence.....simply insert a “*” where ever you need a 1 second pause. Insert “**” if you need a 2 second pause.
- Remember to program a **1** before any long distance numbers.
- Remember to program any **AREA CODE** numbers if needed.
- Remember to program any **PREFIX NUMBERS** (like 9 to get an outside line) if needed.
- *If a new number is programmed into the system, all old numbers will be erased.*

Step 1: Write out the numbers - use the worksheet on page 13. Below we will refer to Number 1 as the first number, Number 2 as the second number etc. Include area-codes and a 1 or 9 if they are needed for dialing.

Step 2: Establish a phone connection with a friend or family member - or with your cell phone. This is done as follows. From your home phone (on the same line as the FreedomAlert is hooked-up to) call your cell phone (or a friend or neighbor if you don't have a cellphone). Answer the phone (or wait until your neighbor answers the phone and tell them just to wait a minute while you program your system).

Note: If you don't do this step, then as you begin to program the unit with your telephone - the phone company will think you are trying to dial an outline number and will try to complete the call. By having the phone line already in use with your cell phone or friend or family member - you are now ready to program the FreedomAlert.

Step 3: With the phone connection established in Step 2, slide the slide switch at the back of the Base unit to “**Learn Mode**”. You will hear an audible announcement of this position.

Step 4:

Telephone Number Programming Worksheet:

Note: You will be using your telephone keypad on an open telephone line to program the emergency call telephone numbers. The base will speak each number that is pushed on the telephones keypad.

Dial Slowly – listen for each number to be announced, if you did not hear the voice announcement – the number was not recorded.

After sliding the switch to LEARN MODE - you must enter the programming password “1 2 3 4 #” before the unit will enter the programming mode.

1. Call a friend or family member on your telephone.
2. Slide switch to LEARN MODE [voice prompt – Learn Mode]
3. Enter: “1 2 3 4 #” [voice prompt – one, two, three, four, “#” - Enter 1st phone number followed by #]

4. (Enter the 1st phone number then “#”) :

_____ #

[voice prompt – numbers as you enter them then “Enter 2nd phone number followed by #]

Press # again to skip remaining numbers, or

5. (Enter the 2nd phone number then “#”)

_____ #

[voice prompt – numbers as you enter them then “Enter 3rd phone number followed by #]

Press # again to skip remaining numbers, or

6. (Enter the 3rd phone number then “#”) :

_____ #

[voice prompt – numbers as you enter them then “Enter 4th phone number followed by #]

Press # again to skip remaining 4th number, or

7. (Enter the 4th phone number then “#”) :

_____ #

[voice prompt – numbers as you enter them]

8. [voice prompt – “End of programming”]

9. Slide switch back to Friends & 911, Friends Only or 911 Only

10. Programming complete!

Programming Special Features

There are a few features you can program into the System. A typical user will not need these features - and may skip to the next page. If you choose to change any of these features - use the same programming set-up as before - i.e. first establish a phone connection with another phone such as. your cell phone. Then slide the switch at the back of the Base to “Learn Mode” - then use these directions for any option you choose to change:

Option #1 – Dial 9 Before Number (important if your phone system requires a 9 before getting an outside line - particularly when it calls 911)

1. Enter **1234**** [Voice prompt – Option Mode]
2. Enter – **1** [Voice prompt – Dial 9 before number, 1 for YES – 3 for NO]
3. Enter either **1** or **3**
[Voice prompt 1 – YES]
or, [Voice prompt 3 – NO] – FACTORY SETTING
4. Enter **#** (to exit programming mode) Voice prompt – Programming complete]
5. Slide Programming Switch to “Friend, 911 – Friends Only – 911 Only”

Option #4 – DEMO/Tradeshow Mode – THIS MODE IS FOR DEMO MODE ONLY FOR SALESPERSONS. This feature is used to DEMO the unit without having access to a telephone line. We use this feature with a Viking DLE-200 test box. NEVER LEAVE THE UNIT IN THIS MODE FOR NORMAL OPERATION.

1. Enter **1234****
[Voice prompt – Option Mode]
2. Enter – **4** [Voice prompt – DEMO Tradeshow Mode],
1 for YES
3 for NO– FACTORY SETTING
3. Enter either 1 or 3
[Voice prompt 1 – YES]
[Voice prompt 3 – NO]
4. Enter “**#**” (to exit programming mode)
[Voice prompt – Programming complete]
5. Slide Programming Switch to “Normal Operation”
[Voice prompt – “Emergency Call Mode”]

Option #5– Delete - “This is an Emergency, Press 5” message (This option is only for special cases. We do not recommend that you change this option without careful thought.)

1. Enter **1234**** [Voice prompt – Option Mode]
2. Enter – 5 [Voice prompt – Play message, This is an emergency, press 5 message, 1 for YES – 3 for NO]
3. Enter either **1** or **3**
[Voice prompt 1 – YES] – FACTORY SETTING
or, [Voice prompt 3 – NO]
4. Enter # (to exit programming mode) [Voice prompt – Programming complete]
5. Slide Programming Switch to “Friend, 911 – Friends Only – 911 Only”

Option #9 – Reset To Factory Settings (This option will ERASE all programmed friend numbers and reset all options.)

1. Enter **1234**** [Voice prompt – Option Mode]
2. Enter – 9 [Voice prompt – Reset to factory settings, 1 for YES – 3 for NO]
3. Enter either **1** or **3**
[Voice prompt 1 – YES] or [Voice prompt 2 – NO]
4. Enter # (to exit programming mode)
[Voice prompt – Programming complete]
5. Slide Programming Switch to “Friend, 911 – Friends Only – 911 Only”

Note: phone numbers are erased so regardless of the switch setting, the unit will call 911 if the emergency button is pushed.

Changing 3-Digit Emergency Contact Number. (This is primarily used when a person is living in another country other than North America where the emergency number is different than 911).

1. Enter **1234*###[** [Voice prompt – Enter New 3 Digit Emergency number]
2. Enter **XXX** (new emergency number)
[Voice prompt – Programming complete]

Adding Additional Pendants to the System.

FreedomAlert comes with one Pendant. If you want to add additional pendants to your system - follow the directions here. If not, skip this section.

The Pendant's unique ID code should already be learned into the Base unit when it came from the factory. You can add a total of 4 Pendants and Emergency Wall Communicators (see available accessories on page 33) to the system by simply learning each pendant's ID code to the Base unit.

To program a new Pendant to the Base unit:

On the Base Unit:

1. Push and release the RED Code Learn button on the back of the base unit. You will hear a voice prompt "Pendant Learning"

On the Pendant:

2. PUSH the Gray Battery Test button and then IMMEDIATELY push the Blue Panic button –HOLD both buttons until you hear "Pendant Learning" from the pendant - then release both buttons on the pendant.
 - If "Base and Pendant out of Range" or "Pendant Learning Failed" is heard from the pendant, stop - wait 30 seconds and start at step #1 again. (Note: For the Emergency Wall Communicator, push and hold the Red "Help" and gray test button).
3. When Pendant learning has been successful you will hear "All Systems are OK" and then it will announce the call setting that the base is set to – Friends 911 Mode, Friends Only or 911 Only.
 - If "Base and Pendant out of Range" or "Pendant Learning Failed" is heard from the Base or Pendant, STOP - wait 30 seconds and start at step #1 again.

Notes:

- You have up to 45 seconds after pushing the RED Code Learn button on the base unit to get the pendant to enter "Pendant Learning" Mode.
- Teaching additional pendants does not erase previously learned pendants.
- The base unit will automatically exit the pendant learning mode after several seconds or if Pendant Learning Failed.
- If you hear the voice prompt "Base and Pendant Out of Range" or "Pendant Learning Failed" an error has occurred, wait 30 seconds for

the base to reset and repeat steps 1 & 2.

- When more than 1 pendant is learned to the base, the base unit will announce the pendant number when doing testing like the battery test.

At a later point in time, you might want to erase your previously learned Pendants. You can erase all previously learned Pendants by simply holding down the red **Code Learn** button at the back of the Base unit for 8 seconds. You will hear the confirmation of “Previous Pendant Codes Erased” from the Base unit. After that, you can program a new Pendant to the base unit following the steps above as desired.

Operating the FreedomAlert:

Operating the Pendant. The Pendant is simple in operation - having one main Blue button - and a smaller Gray button on the back.

The Blue button on the front is the main button to push for a full 2 seconds to initiate a call. Once this button is pushed the call proceeds forward to the ‘Friends’ list and or 911 depending on the slide switch setting on the back of the Base unit.

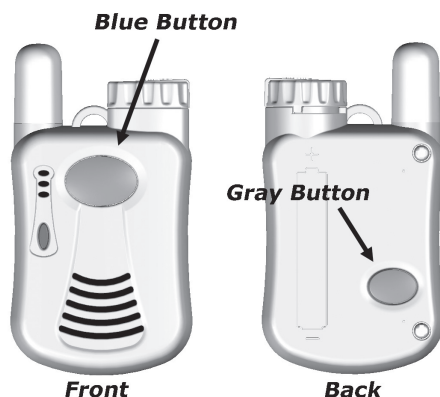



Holding the Pendant. At this point - you simply hold the Pendant as you would any normal telephone receiver - close to the head so that you can hear the other person being called - and they can hear you speaking.

Hanging -Up. If you choose to cancel the call once initiated - you can simply push the Gray button on the back for a second to cancel the call and you will hear “Hanging up”. If at the end of the conversation, the other side can force a hang up by pushing “9”, or the just hang up their end, and the system will hang-up automatically over the next 1 to 3 minutes, or you can push the gray button on the Pendant to end the call immediately. The unit will automatically reset and be ready for the next call.

Answering an Incoming Call with the Pendant:

The FreedomAlert has the ability to answer incoming calls through the pendant or the Emergency Wall Communicator accessory. Once the customer hears the phone ring (the pendant will NOT ring), they simply push the Blue Emergency button or Red “HELP” button on the Emergency Wall Communicator to answer the call. Example:

1. Incoming call to customers home
2. Base unit rings
3. Push the Blue Emergency button on pendant for 2 seconds to activate the pendant
4. FreedomAlert will answer the incoming call – talk using pendant
5. To end the call
 - a. User pushes the Gray test button on pendant to hang-up.
 - b. Or, the calling person pushes #9 to end call and reset unit
 - c. Or, the unit listens for 3 minutes of silence and then hangs-up and resets

Lanyard, Belt Clip or Wrist Strap.

FreedomAlert comes with 3 accessories for carrying the pendant . You can carry the Pendant using the Lanyard. You can slide the Pendant in the Belt Clip, or you can use the Wrist-strap as a means to carry the Pendant. Note that the Wrist-Strap can also be used as a way to attach the Pendant to a wheel chair. Choose the method that suits you best.

The drawing at the right shows the method of attaching the lanyard to the Pendant.

NOTE: This lanyard has a 'break-away' feature in the event it gets tangled on something in a fall.

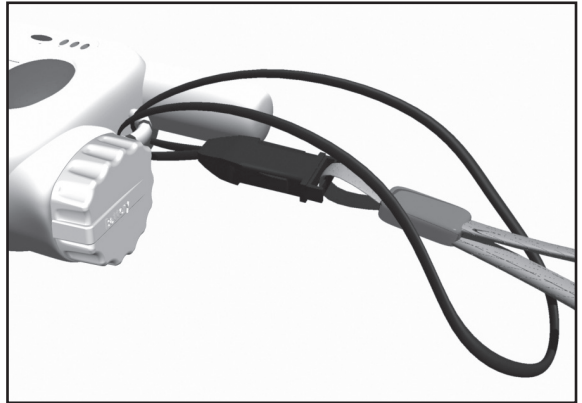

Battery Check:

The FreedomAlert has a built-in battery tester. When you press and release the Gray button at the back of the Pendant, a voice announcement will inform you of the battery condition. One of the following messages will be heard:

“Battery is ok.”

Check the battery condition twice a month.

“Battery is low.”

The battery should be replaced within the next week.

“Replace battery now.”

The battery should be replaced now.

To replace the battery - simply exchange the battery in the Pendant with the battery that has been charging in the Base unit.

Please note: If there is no response after pressing the button for one second or more, the battery is dead and must be replaced immediately.

The battery should be tested at least twice a month along with the System Check outlined on the this page.

When it gets to the point after a few years that the pendant battery only lasts 4 weeks before needing to be charged - it is then time to replace both the Pendant batteries. Note: This is a very unusual battery not available at most outlets. Order replacement batteries from LogicMark as directed on page 33.

NOTE: The pendants are monitored by the base unit. The pendant reports to the base every 13 hours. If the battery condition is “Replace Battery Now”, the base unit will call the first ‘Friend’ number and play the voice prompt [Pendant number X, Replace Battery Now]. The voice prompt is played 10 times, then hangs up and resets.

And, if the base unit misses 4 reports from the pendant in a row (52 hours), the base unit will call the first ‘Friend’ number and play the voice prompt [Pendant Number X, Not in communication]. The voice prompt is played 10 times, then hangs up and resets.

Pressing the 9 on the phone keypad on either of these messages will stop the announcement and cause the unit to reset.

If the first ‘Friend’ gets either of these announcements, please make arrangements as soon as possible to service or replace the pendant.

The unit will not call 911 to report a Replace Battery Now or Pendant Failed condition. A ‘Friend’ number must be programmed for this feature to work.

System Check:

The gray button on the back of the pendant case which is used to perform the BATTERY CHECK, will also perform a SYSTEM CHECK. Press and hold this button for more than four (4) seconds. One of the following announcements will be made.

“All systems are ok.”

This confirms the following:

Battery status.

The Pendant is working.

The Base unit is working.

The Base unit is connected to a working phone line.

The Pendant is within range of the Base unit.

“System cannot detect dial tone.”

The Base unit is not connected to the phone line or can not get a dial tone for some reason.

“Base and Pendant out of range.”

This confirms one or more of the following:

The Pendant has malfunctioned.

The Base has malfunctioned.

The Pendant and Base unit are not communicating with each other or are out of range.

If you receive a failure notification, please refer to the TROUBLESHOOTING guide on page 24 of this manual to determine the cause.

This testing feature is very useful - allowing you to confirm that the system has coverage from all parts of your home. Simply walk to the various parts of your home and push the Battery Check / System Check button until you hear the 4 beeps and then the dial tone. You can then release the button, and you will hear the voice prompt “All Systems are OK”, “Pendant and Base out of Range”, or “System Cannot Detect Dial Tone”.

NOTE: If your telephone service offers voice mail and the voice mail system uses a Stutter Dial Tone to notify you of a message, the system test may fail – “cannot detect dial tone” if a system test is made with a message waiting. This is normal as the FreedomAlert is “listening” for a conventional dial tone. Check your messages so the dial tone returns to a solid tone and test again. In the event of an emergency, the FreedomAlert will dial the emergency number regardless of a standard or stutter dial tone.

Caution - To ensure proper operation, this equipment must be installed according to these instructions. We highly recommend that you perform this System Check after set-up and installation and at least twice a month to confirm that your system is working properly and that the pendant and base unit are in good communication and that the base unit can get a dial tone. It is also recommended to perform this system check after a lightning storm that could damage the base unit which is plugged into the phone line.

Emergency Dialing Using the Pendant:

In the event of an emergency, press the blue panic button on the front of the Pendant. When this button is pressed for 2 seconds, the FreedomAlert will automatically start dialing from the list of numbers.

If set to the “911 only” mode, then the 911 emergency operator will be called. When the emergency response operator answers, speak in a normal voice and you will be heard.

If set to the “Friends only” mode - the system will dial the first telephone number in the list. If no one is available for that number, it will dial the second number, etc - until it gets to the end of the list. It will then repeat from the top of the list.

If set to the “Friends and 911” mode - the system will dial the first telephone number in the list. If no one is available for that number, it will dial the second number, etc - until it gets to the end of the list. After that, it will then dial the 911 emergency operator.

Operating Range:

The operating range of your FreedomAlert will depend on many factors including intervening walls, electrical interference or various appliances such as vacuum cleaners, microwave ovens, mixers, coffee grinders, hair dryers and other sources of electrical noise around the house. The system should cover your typical home and a short distance into the front, side and back yards. Perform the System Check on page 20 to determine the boundaries of your system to know the limits of operation in your home and surroundings.

Water Resistance:

FreedomAlert will resist splashes from water - i.e as in the shower. However, it should never be submerged or exposed to water continuously.

Periodic Testing / Maintenance

It is highly recommended that you preform a full System Check (see page 20) at least twice a month. This will confirm that the Pendant battery is in good condition and that the Base unit is able to get a dial tone.

Replacing Batteries: Replace the Base unit batteries every 2 years - or as needed. Be sure to purchase NiMH AA batteries with 2400 mAh or greater capacity. A set of batteries in good condition and fully charged will supply 24 hours of back-up in the event of a power outage. You can test this by unplugging the AC Adapter and hearing the voice prompts. When the unit is operating on the backup batteries, it will announce “Running On Battery Power” twice and the RED Power LED will continue to flash. If power is not restored within an 8 hour period, the unit will start to announce “Running On Battery Power” once every 30 minutes until power is restored or the back up batteries are depleted. (Note that lower capacity batteries can be used - but they will give less back-up time).

Out of Service Storage or Transportation: When storing the Base unit -or taking it on a trip - or sending it in for repair - it is recommended that you turn the Master ON/OFF switch to OFF so that the “Running on battery power” announcement for the next 24 hours doesn’t drive the postmaster crazy. Remember to turn the Master ON / OFF switch to ON when it is put back in service.

Caution - This equipment cannot call out when other equipment (telephone or a computer modem, etc.) are in use on the same phone line. Having said that however, you can be comforted that in the event someone is on the telephone elsewhere in the home when you push the Freedom-Alert button for an emergency situation - even though you cannot call out - you will be connected to the person on the telephone line in your home. And thus can communicate with them.

TROUBLESHOOTING GUIDE

What if I can't get the FreedomAlert to work?

Step 1 – Push the gray RESET button with a pen at the back of the base unit (next to the power cord). Check the system. If it is now working skip the remaining steps.

Step 2 – Check the PENDANT.

What to do:

Press the Gray Battery Test / System Check button on the back of the Pendant.

What to expect:

A voice should announce the condition of the battery.

A light on the front of the Pendant will come on.

If nothing happens, the most likely cause is that the battery is dead or has been installed backwards.

If the Pendant says “Battery ok”, go on to step 3.

Step 3 – Check the connections on the BASE UNIT

What to do:

Make sure the AC Adapter is plugged into a live AC outlet and into the Base unit.

Make sure the Master ON / OFF switch is ON

What to expect:

The Red POWER light will be on if the Base unit is connected to power.

If the POWER light is on and the Base unit is connected to a working phone line, go on to step 3.

Step 4 – Make sure the Pendant and the Base unit are communicating with each other.

Background information: The Pendant and the Base unit are connected by a wireless radio link. They must be synchronized to work together. They should have already been synchronized at the factory, but resetting this is simple.

What to do:

Follow the steps on page 16: Adding Additional Pendants to the System

Now perform the System Check test again (page 20) to make sure all is well.

If your FreedomAlert is still not working, call our TECH SUPPORT department at 703-934-7934.



Intertek
4002013

CONFORMS TO
UL STANDARDS #1637

Information The FCC Wants You To Know:

FCC ID: TYD3X911

This device complies with Part 15 of the FCC Rules. Operation is subject to the following two conditions: (1) this device may not cause harmful interference, and (2) this device must accept any interference received, including interference that may cause undesired operation.

Privacy of communications may not be ensured when using this product.

NOTE: This equipment has been tested and found to comply with the limits for a Class B device, pursuant to Part 15 of the FCC Rules. These limits are designed to provide reasonable protection against harmful interference in a residential installation. This equipment generates, uses and can radiate radio frequency energy and, if not used in accordance with the instructions, may cause harmful interference to radio communications. However, there is no guarantee that interference will not occur in a particular installation. If this equipment does cause harmful interference to radio or television reception, which can be determined by turning the equipment off and on, the user is encouraged to try to correct the interference by one or more of the following measures:

- Reorient or relocate the receiving antenna.
- Increase the separation between the equipment and receiver.
- Connect the equipment into an outlet on a circuit different from that to which the receiver is connected.
- Consult the dealer or an experienced radio/TV technician for help.

Canada IC: 8471A-3X911 This Class B digital apparatus complies with Canadian ICES-003.

This equipment also complies with Part 68 of the FCC rules and the requirements adopted by the ACTA:

US:TYDW400B3X911

REN: 0.0B

- a) On the bottom of this equipment is a label that contains, among other information, a product identifier - in this case, US:TYDW400B3X911. If requested, this number must be provided to the telephone company.
- b) An applicable certification jacks Universal Service Order Codes (USOC)

for the equipment is provided (i.e. RJ11C) in the packaging with each piece of approved terminal equipment.

c) A plug and jack used to connect this equipment to the premises wiring and telephone network must comply with the applicable FCC Part 68 rules and requirements adopted by the ACTA. A compliant telephone cord and modular plug is provided with this product. It is designed to be connected to a compatible modular jack that is also compliant. See installation instructions for details.

d) The Ringer Equivalent Number (REN) is used to determine the number of devices that may be connected to a telephone line. Excessive RENs on a telephone line may result in the devices not ringing in response to an incoming call. In most but not all areas, the sum of the RENs should not exceed five (5.0). To be certain of the number of devices that may be connected to a line, as determined by the total RENs, contact the local telephone company. Since our product has no ringer - the REN equals 0.0.

e) If this equipment (model 35911) causes harm to a telephone network, the telephone company will notify you in advance that temporary discontinuance of service may be required. But if advance notice isn't practical, the telephone company will notify the customer as soon as possible. Also, you will be advised of your right to file a complaint with the FCC if you believe it is necessary.

f) The telephone company may make changes in its facilities, equipment, operations or procedures that could affect the operation of the equipment. If this happens the telephone company will provide advance notice in order for you to make necessary modifications to maintain uninterrupted service.

g) Should you experience trouble with this equipment, please contact Logic-Mark at 703-934-7934 for repair or warranty information. If the equipment is causing harm to the telephone network, the telephone company may request that you disconnect the equipment until the problem is resolved.

h) Please follow instructions for repairing if any (e.g. battery replacement section); otherwise do not alternate or repair any parts of device except specified.

i) Connection to party line service is subject to state tariffs. Contact the state public utility commission, public service commission or corporation commission for information.

j) NOTICE: If your home has specially wired alarm equipment connected to the telephone line, ensure the installation of this model 35911 does not disable your alarm equipment. If you have questions about what will disable alarm equipment, consult your telephone company or a qualified installer.

General Warnings And Precautions!

Warning!

- LogicMark, LLC DOES NOT represent this unit to be waterproof. To reduce the risk of damage to the unit, DO NOT expose the pendant or base unit to prolonged water, rain or moisture.
- FreedomAlert is intended for residential use only. It may not work properly if connected to some commercial phone systems.
- FreedomAlert works with tone dialing systems only. Do not use if you have pulse dialing only.
- This product and/or accessories may contain lead, a chemical known to the State of California to cause birth defects or other reproductive harm.

Note: FreedomAlert does not interfere with pacemakers.

Important Safety Instructions:

When using your FreedomAlert , please observe the following instructions in order to reduce the risk of personal injury, electrical shock, or fire.

1. Save these instructions for future reference.
2. Read all instructions carefully and make sure you understand them.
3. Unplug this product from the electrical outlet before attempting to clean it. Do not use any liquids for cleaning either the Base unit or the Pendant. Use only a soft damp cloth.
4. Do not locate the Base unit near any source of water, such as in the bathroom, near a sink in the kitchen, or the like.
5. Do not open the unit, (except the battery compartments as directed in these instructions) on the Pendant for any reason. Any attempt to open the case of the Base unit or the Pendant will void the warranty and may damage the unit or prevent it from working properly.
6. Do not use any power source other than that supplied from LogicMark, LLC specifically for this product. Use of any other power source could damage your unit or make it unsafe.
7. Always dispose of batteries properly. Never thrown batteries into a fire. Consult your local ordinances for proper battery safety.
8. If your unit becomes damaged do not attempt to repair it. Please return it to LogicMark, LLC for service or replacement as stipulated on the next page under “ONE YEAR LIMITED WARRANTY”.

LogicMark Disclaimers and Limited Warranty

COMMUNICATION AND RESPONSE LIMITATIONS: Purchaser acknowledges that signals which are transmitted over telephone lines, or other modes of communication pass through communication networks wholly beyond the control of LogicMark LLC and are not maintained by LogicMark LLC, and, therefore, LogicMark LLC shall not be responsible for any equipment or communication failure which prevents transmission signals from reaching your contact list including emergency 911 operators or damages arising therefrom. **Purchaser acknowledges that LogicMark LLC provides no response to its FreedomAlert equipment.** The equipment is designed to communicate with the contact list of your choice as well as emergency 911 operators and LogicMark LLC is not and shall not be responsible for ambulance, police or other emergency response time or that any response will be provided by the anyone on your contact list including the emergency 911 response center.

ELECTRIC AND TELEPHONE SERVICE IS NECESSARY AND PURCHASER'S RESPONSIBILITY: Purchaser acknowledges that the FreedomAlert equipment (including optional Battery Back-up accessory) plugs into a standard land line telephone jack and communicates over standard telephone lines using two way voice communication. You must use a special adaptor (not supplied) for the equipment to work with VOIP Internet transmission. VOIP Internet will not work when your electricity service is interrupted unless you have battery back up for your computer. Purchaser acknowledges that the FreedomAlert equipment requires 110 Volt AC power and electrical outlets and receptacles, telephone hook-ups, RJ11 Block or equivalent, all of which is Purchaser's responsibility to obtain and maintain.

TESTING AND SERVICE OF FreedomAlert EQUIPMENT: The FreedomAlert equipment, once installed, are in the exclusive possession and control of the Purchaser, and it is Purchaser's sole responsibility to test the operation of equipment and request warranty service if the equipment is under warranty.

PURCHASER’S EXCLUSIVE REMEDY: Purchaser’s exclusive remedy for LogicMark LLC’s default hereunder is to require LogicMark LLC to repair or replace, at LogicMark LLC’s option, any equipment or part of the personal emergency alert system which is non-operational during LogicMark LLC’s warranty period.

LIMITATION OF LIABILITY: The FreedomAlert equipment is not designed or guaranteed to prevent any loss or injury. This Limited Warranty and Disclaimer of Liability constitutes the terms of sale and use of the FreedomAlert (and accessory) equipment, and if, notwithstanding these terms of sale and use of the product, there should arise any liability on the part of LogicMark LLC as a result of any cause whatsoever, regardless of whether or not such loss, damage, or personal injury was caused by or contributed to by LogicMark LLC’s negligence to any degree or failure to perform any obligation or strict products liability, such liability will be limited to an amount paid by the Purchaser to LogicMark LLC for the product, or to the sum of \$300.00, whichever is greater.

ONE YEAR LIMITED WARRANTY

Warranty: LogicMark, LLC warrants to the original consumer/purchaser that this product shall be free of defects in material and workmanship under normal use and circumstances for a period of **one (1)** year from the date of original purchase for use.

How to Get Warranty Service: When the original consumer/purchaser returns the product pre-paid to LogicMark, LLC; 8625 Hampton Way; Fairfax Station, Virginia 22039, USA within the warranty period, and if the product is defective, LogicMark, LLC will at its option repair or replace such.

Warranty Limitations and Exclusions: LogicMark LLC does not represent nor warrant that the FreedomAlert system will prevent any loss, damage or injury to person or property, or that the personal emergency alert system will in all cases provide the protection for which it is installed or intended. Purchaser acknowledges that LogicMark LLC is not an insurer, and that Purchaser assumes all risk for loss or injury to Purchaser’s property or person. LogicMark LLC has made no representation or warranties, except those expressed herein and hereby disclaims any express warranty of merchantability or fitness for any particular use.

LogicMark, LLC. will not be responsible for the improper use of FreedomAlert, nor will it be responsible for failure resulting from the use of other equipment connected to the same phone line. We will not be responsible for the quality of the phone line or the reliability or quality of the phone service with which FreedomAlert is used. LogicMark, LLC. will not be responsible for the installation of the FreedomAlert. It will not be responsible for the improper use or abuse of the base unit or pendant.

This warranty shall constitute the sole liability of LogicMark, LLC concerning the product. ALL IMPLIED WARRANTIES INCLUDING, WITHOUT LIMITATION, THE WARRANTIES OF MERCHANTABILITY AND FITNESS FOR A PARTICULAR PURPOSE ARE LIMITED IN DURATION TO THE TERM OF THIS EXPRESSED ONE YEAR LIMITED WARRANTY. NO PERSON, FIRM, OR CORPORATION IS AUTHORIZED TO ASSUME FOR LogicMark, LLC. ANY OTHER LIABILITY IN CONNECTION WITH THE SALE AND USE OF THE PRODUCT. LogicMark, LLC AND AGENTS AND DISTRIBUTORS WILL BEAR NO LIABILITY WHATSOEVER FOR INCIDENTAL OR CONSEQUENTIAL DAMAGES OR CHARGES OF ANY KIND

This warranty is void if the product has been damaged or tampered with or if the product or any such parts have been opened. In all cases of damage during shipment, a claim must be filed with the shipping carrier and not with LogicMark, LLC.

State Law: This warranty gives you specific legal rights; you may also have other rights which vary from state to state. Some states do not allow the exclusion or limitation of incidental or consequential damages, or a limitation on the duration of implied warranties, so the above disclaimers may not apply to you.

OUT OF WARRANTY REPAIRS

If the warranty period has expired or if you are not the original owner of the product, LogicMark, LLC will at its option either (1) replace this product with a functionally similar (but not necessarily identical) refurbished product or (2) repair the original product and return it to the original consumer/purchaser after payment of repair/replacement charges has been received.

Replacement Parts / Optional Accessories:

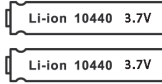

**Rechargeable Li-Ion Special
Pendant Batteries 2 Pieces**
Part #35917 \$15.00



**Rechargeable AA Batteries
4 Pieces**
Part #35918 \$15.00



Lock Box
Part #30913 \$34.95



Extra Pendants
Part #35915 \$119.95



Emergency Wall Communicator
Part #37920 \$119.95
**This wall button can permanently
mount to the bedroom or bathroom
wall - and provide the same 2-way voice
communication just like the Pendant in
an emergency..**

All prices are in US dollars and include shipping and handling to the 50 United States. Add an additional \$7.00 for Canadian shipments. Orders can be sent in with a check or credit card information. Include your full mailing address and telephone number. Orders can also be placed via telephone at 1-800-519-2419.

Always include your pendant and base serial # (on the bottom of the case) when ordering. Or have it ready when you call in.

Product Specifications:

RF Technology:	1.9 Ghz DECT System
Operating Range	Covers your typical American house and into the front, back, and side yards.
Power Adapter Ratings	Input: 110 VAC Output: 7.5 volts DC - 500 mA
Base Unit Power Consumption	120 mA in standby mode 200 mA when dialing
Back-up Battery Supply	AA NiMH 2400 mAh batteries (4 pieces). Should be replaced every 2 years. (Note that lower or larger capacity batteries can be used - they will just give less or more back-up supply time).
Back-up Operation Duration	24 hours with freshly charged batteries
Dialing Style	Touch-Tone only
Telephone Number Length	32 digits maximum
Telephone Numbers	Can learn up to 4 numbers plus the 911 emergency number already programmed.
Pendant Battery Life on Full Charge	More than 4 months in standby More than 1 hour of talk time.
Pendant Batteries	3.6 or 3.7 volt 350 mAh Li-Ion (2 pieces) Battery size 10440. Should be replaced every 2 years Purchase replacements from LogicMark Or, available on line at www.PrimaryVolt.com
Pendant water-resistance	Water Spray Standard IPX5 (shower only).
Number of Pendants/Base Unit	Up to a total of 4 Pendants or Emergency Wall Communicators can be programmed to one Base unit.
Operating Temperature	32° to 120° F. (0° to 49° C).



Intertek
4002013

CONFORMS TO
UL STANDARDS #1637

LogicMark

8625 Hampton Way;
Fairfax Station, Virginia 22039

Tel: 1-703-934-7934

Toll Free: 1-800-519-2419

Fax: 1-703-934-7935

www.LogicMark.com

FreedomAlert is covered by the following patents:
US # 5,521,582 & Canadian # 2,080,921
Other patents pending

©2011 LogicMark, LLC